

JEWELRY ROTARY TUMBLER

INSTRUCTIONS AND PARTS LIST

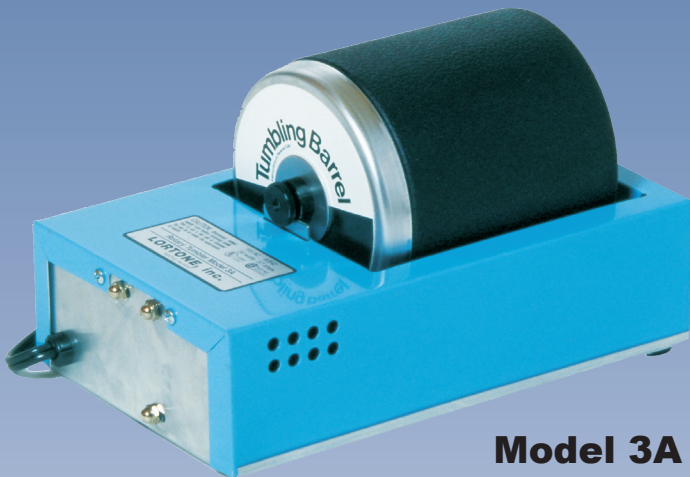

Model 3A

LORTONE

12130 Cyrus Way
Mukilteo, WA 98275
(425) 493-1600

GETTING STARTED

- I. **Open the Barrel:** Remove nut and washer, press down on bolt with thumb while lifting up on outside of outer lid with fingers. If outer lid is difficult to remove, insert washer between edge of outer lid and barrel, twist to loosen. After outer lid has been removed, lift inner lid out by center bolt.

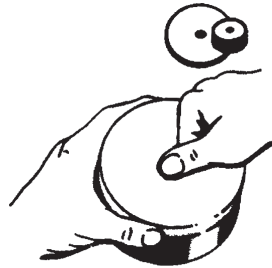

- II. **Add Tumbling Media:** Put 1 lb. Stainless Steel Shot mix in barrel.



- III. **Add Jewelry:** Add pieces of jewelry to barrel. Add water to top layer of Jewelry and Shot mix (barrel should not weigh more than 4 lbs. full). Add a drop or two of dish washing soap. Do not add more than 2 drops of soap or damage to barrel and leakage may occur.

- IV. **Close the Barrel:** Wipe the mating surfaces of the barrel and inner lid clean with a damp cloth. Press inner lid into barrel until it rests on shoulder. Press outer lid firmly down onto the barrel. Install washer and tighten nut.

Knurled nut only needs to be snug Do Not Use tools to tighten. Over tightening of the nut can cause the inner lid to distort and leak.

Make sure to align barrel guide with groove in black knurled nut.

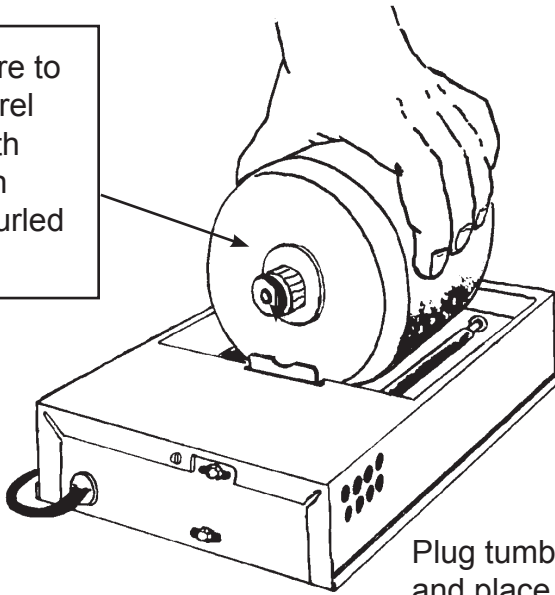

Plug tumbler in and place barrel on tumbler.

- V. Tumble:** Plug the tumbler into a suitable outlet. Place the barrel on the tumbler making sure the groove in the barrel nut sits on the tumbler guide. Tumble for a 1/2 hour. Open and check the jewelry. Tumble longer if necessary to achieve the desired finish.
- VI. Clean up:** Empty contents of barrel in a mesh strainer, careful not to lose any shot. Do not re-use liquid. Rinse shot and jewelry. Once jewelry pieces are removed, spread out shot mix to dry. Make sure that the stainless steel shot mix is completely dry before storing.

CAUTION:

Do not tumble jewelry containing stones. Stones are susceptible to chipping, fracturing and scratches that can be caused by the jewelry and shot mix.

MAINTENANCE

LORTONE Tumblers are capable of operating 24 hours/ day for years with proper care.

For best operation and results follow these simple, but important steps:

MOTOR: The motor is designed for continuous use and does not need oiling or other maintenance. It is normal for the motor to run hot to the touch.

CLEANING: The outside of the barrel should be kept clean. Clean by wiping with a wet soapy cloth and rinse well with fresh water. DO NOT put the barrel in a dishwasher or clean using solvents. If the outside of the barrel becomes so slick that it slips on the rollers, roughen slightly with very fine sandpaper or steel wool.

BEARINGS: Oil each shaft bearing every 30 days of operation, using one drop of lightweight lubricating oil. Do Not Use excessive oil.

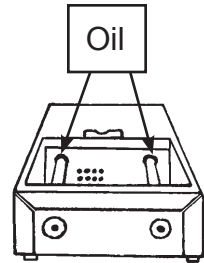

DRIVE BELT: Keep the drive belt tight enough to drive the barrel without being over tightened. Improper tension (too tight) can cause motor bearing failure and belt stretch. To adjust the belt, loosen the two motor mounting nuts, slide the motor to the right, and re-tighten the nuts.

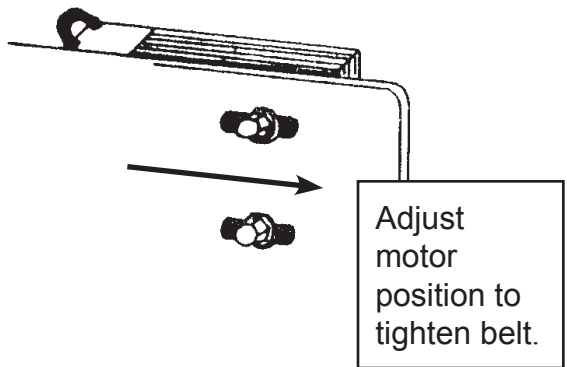

TROUBLESHOOTING

If your tumbler fails to operate correctly, check the following:

Barrel does not turn, turns very slowly, or stops after being placed on tumbler.

No Power to unit.	Make sure machine is plugged in correctly. Make sure electrical circuit is operational.
Barrel not installed correctly.	Align Barrel correctly.
Barrel Too Heavy.	Do not exceed rated capacity.
Belt Slipping.	Tighten Belt.
Drive Belt Broken.	Remove Cover and Replace Belt.
Motor doesn't run or runs intermittently.	Replace motor.

Barrel leaks or barrel lid comes off during operation.

Inner lid not seated correctly.	Make sure inner lid and barrel shoulder are clean and free of contaminants. Make sure inner lid is seated on shoulder inside barrel.
Knurled Nut over tightened.	Tighten Knurled Nut by hand only until snug. Do not use tools.
Bubble build-up in barrel.	Do not use more than two drops of dish washing soap.
Barrel or Boot Gasket damaged.	Replace damaged barrel or boot gasket.

If you need assistance, please contact:
Lortone Customer Service (425) 493-1600
equipment@Lortone.com

PARTS LIST

Part No.	Description
A 001-005	Top Cover
B 001-006	Base
C 001-007	Drive Shaft
D 001-008	Idler Shaft
E 203-004	Bearing, Open End (1 Required)
F 203-003	Bearing, Closed End (3 Required)
G 001-101	Drive Pulley Assembly
H 001-100	Motor Pulley With Fan
I 206-012	Retaining Ring
J 210-001	Drive Belt
K 301-034	Motor, 110v
K 301-035	Motor, 220v
L 350-003	Cord, EU, 220v
L 350-004	Cord, UK, 220v
L 350-005	Cord, USA, 110v
L 350-010	Cord, Aus/NZ, 220v
M 320-001	Strain Relief, 110v
M 320-002	Strain Relief, 220v
Part No.	Description
020-091	Complete Rubber Barrel Assembly
N 020-100	Inner Lid
O 020-001	Outer Lid
P 481-070	Knurled Nut
Q 240-010	Boot Gasket
R 240-002	Rubber Barrel Only
S 108-001	Barrel Washer
T 592-037	Stainless Steel Shot

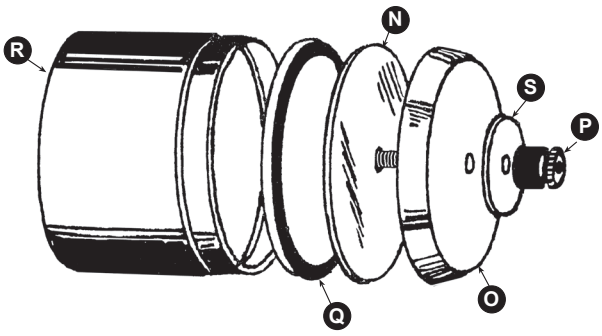
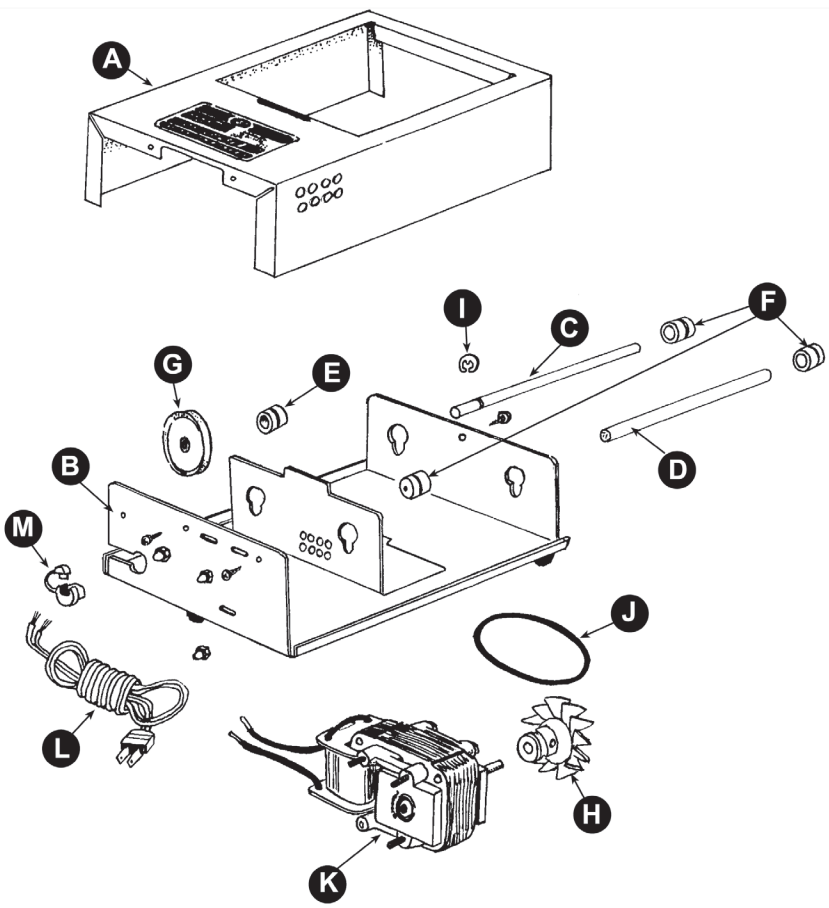

LORTONE Rotary Tumblers
are quiet, durable grinding
and polishing machines.
Follow these basic operating
and care instructions to help
keep your tumbler in optimal
running condition.

LORTONE

12130 Cyrus Way
Mukilteo, WA 98275
(425) 493-1600